

DUCTILE IRON EPOXY PRESSURE REDUCING VALVE PN16

Model: 200X-16Q

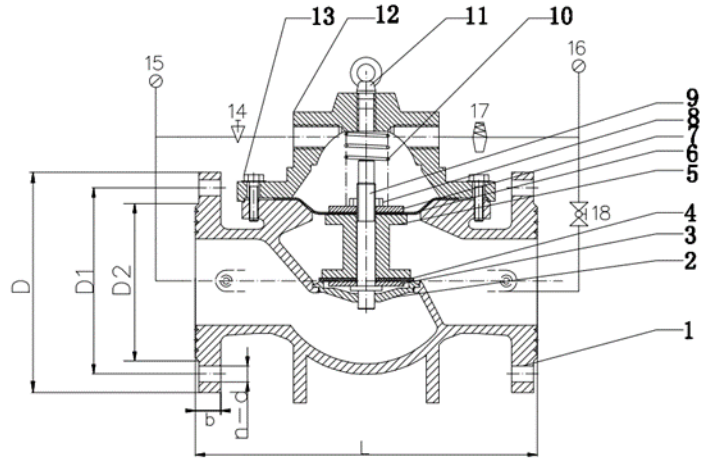

STANDARD MATERIALS OF MAIN PARTS

ITEM	PART NAME	MATERIAL	ITEM	PART NAME	MATERIAL
1	BODY	DUCTILE IRON	10	SPRING	STAINLESS STEEL
2	SEAT	BRASS	11	EYE BOLT	CARBON STEEL
3	PLATEN	CARBON STEEL	12	BONNET	DUCTILE IRON
4	SEAL	EPDM	13	BOLTS	STAINLESS STEEL
5	DISC	DUCTILE IRON	14	NEEDLE VALVE	BRASS
6	DIAPHRAGM	EPDM	15	PRESSURE GAUGE	WITHOUT
7	PLATEN	CARBON STEEL	16	PRESSURE GAUGE	WITHOUT
8	NUT	STAINLESS STEEL	17	PILOT VALVE	BRASS
9	STEM	STAINLESS STEEL	18	BALL VALVE	BRASS

TECHNICAL DATA

SPECIFICATION STANDARDS

Design according to: Manufacture standard
Flange end standard: DIN PN16 (BS4504 PN16)
Inspection and testing standard: API 598
Nominal pressure: 1.6 MPa
Test pressure shell: 2.4 MPa
Test pressure seal: 1.76 MPa
Working temprature: Max 80°C
Applicable medium: Water

DIMENSION (mm)

DN	L	D	D1	D2	n-Ød	b
DN50	218	150	125	86	4-Ø19	16
DN65	230	180	145	130	4-Ø19	17
DN80	255	195	160	135	8-Ø19	18
DN100	285	212	180	153	8-Ø19	18
DN125	324	245	210	183	8-Ø19	18
DN150	365	278	240	205	8-Ø23	20
DN200	425	335	295	260	12-Ø23	25